

SD5620/5630

Optoschmitt Detector

FEATURES

- TO-46 metal can package
- 6° (nominal) acceptance angle
- TTL/LSTTL/CMOS compatible
- High noise immunity output
- Buffer (SD5620) or inverting (SD5630) logic available
- Two sensitivity ranges
- Mechanically and spectrally matched to SE3450/5450, SE3455/5455 and SE3470/5470 infrared emitting diodes

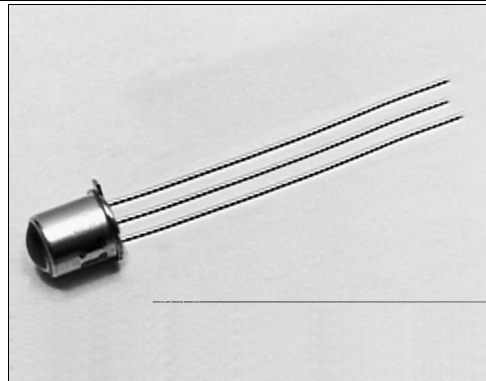

INFRA-81.TIF

DESCRIPTION

The SD5620/5630 series is family of single chip Optoschmitt IC detectors mounted in a TO-46 metal can package. The photodetector consists of a photodiode, amplifier, voltage regulator, Schmitt trigger and an NPN output transistor with a 10 kΩ (nominal) pull-up resistor. Output rise and fall times are independent of rate of change of incident light. Detector sensitivity has been internally temperature compensated. The TO-46 package is ideally suited for operation in hostile environments.

Device Polarity:

- Buffer - Output is HI when incident light intensity is above the turn- on threshold level.
- Inverter - Output is LO when incident light intensity is above the turn- on threshold level.

OUTLINE DIMENSIONS in inches (mm)

Tolerance 3 plc decimals ±0.005(0.12)
2 plc decimals ±0.020(0.51)

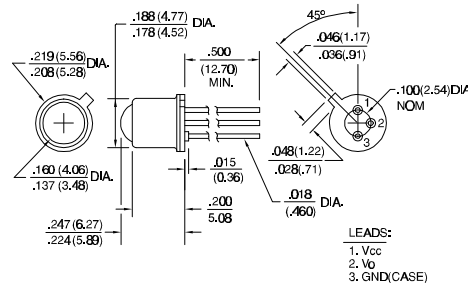

DIM_025.cdr

SD5620/5630

Optoschmitt Detector

ELECTRICAL CHARACTERISTICS (-40°C to +100°C unless otherwise noted)

PARAMETER	SYMBOL	MIN	TYP	MAX	UNITS	TEST CONDITIONS
Operating Supply Voltage	V _{CC}	4.5	16.0		V	T _A =25°C
Turn-on Threshold Irradiance ⁽²⁾ SD5620-001, SD5630-001 SD5620-002, SD5630-002	E _{ET(+)}		0.25 0.13		mW/cm ²	V _{CC} =5 V T _A =25°C
Hysteresis ⁽³⁾	HYST	5	30		%	
Supply Current	I _{CC}		12.0 15.0		mA	E _e =0 Or 3.0 mW/cm ² V _{CC} =5 V V _{CC} =16 V
High Level Output Voltage SD5620 SD5630	V _{OH}	2.4 2.4			V	V _{CC} =5 V, I _{OH} =0 E _e =3.0 mW/cm ² E _e =0
Low Level Output Voltage SD5620 SD5630	V _{OL}		0.4 0.4		V	V _{CC} =5 V, I _{OL} =12.8 mA E _e =0 E _e =3.0 mW/cm ²
Internal Pull-Up Resistor	R _{INT}	5.0	10.0	20.0	kΩ	
Operate Point Temperature Coefficient	OPTC		-0.76		%/°C	Emitter @ Constant Temperature
Output Rise Time	t _r		60		ns	R _L =390 Ω, C _L =50 pF
Output Fall Time	t _f		15		ns	R _L =390 Ω, C _L =50 pF
Propagation Delay, Low-High, High-Low	t _{PLH} , t _{PHL}		5.0		μs	R _L =390 Ω, C _L =50 pF
Clock Frequency				100	kHz	R _L =390 Ω, C _L =50 pF

Notes

- It is recommended that a bypass capacitor, 0.1 μF typical, be added between V_{CC} and GND near the device in order to stabilize power supply line.
- The radiation source is an IRED with a peak wavelength of 935 nm.
- Hysteresis is defined as the difference between the operating and release threshold intensities, expressed as a percentage of the operate threshold intensity.

ABSOLUTE MAXIMUM RATINGS

(25°C Free-Air Temperature unless otherwise noted)

Supply Voltage	16 V ⁽¹⁾
Duration of Output Short to V _{CC} or Ground	1.0 sec.
Output Current	18 mA
Operating Temperature Range	-40°C to 100°C
Storage Temperature Range	-55°C to 125°C
Soldering Temperature (10 sec)	260°C

Notes

- Derate linearly from 25°C to 7 V at 100°C.

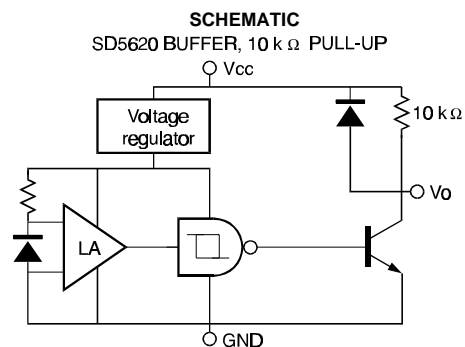

Honeywell reserves the right to make changes in order to improve design and supply the best products possible.

Honeywell

SD5620/5630

Optoschmitt Detector

SCHEMATIC

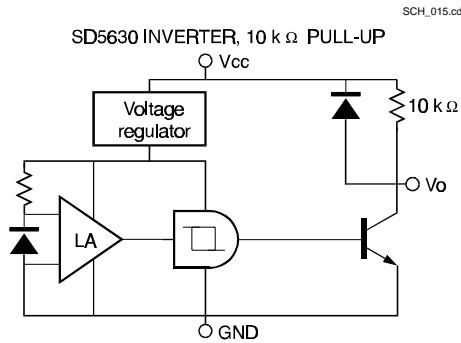

SWITCHING TIME TEST CIRCUIT

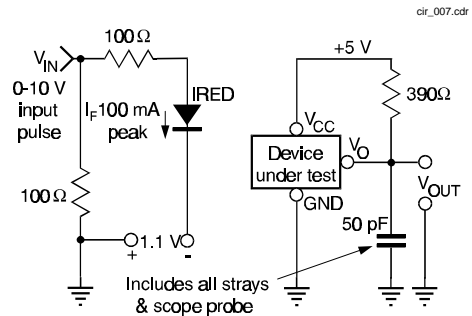

SWITCHING WAVEFORM FOR BUFFERS

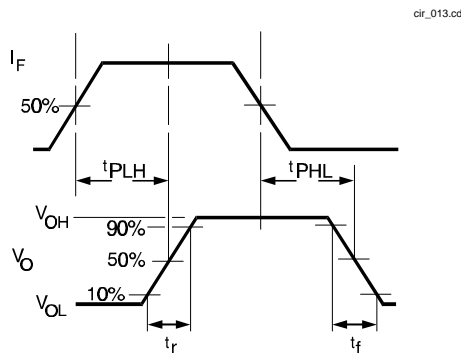

SWITCHING WAVEFORM FOR INVERTERS

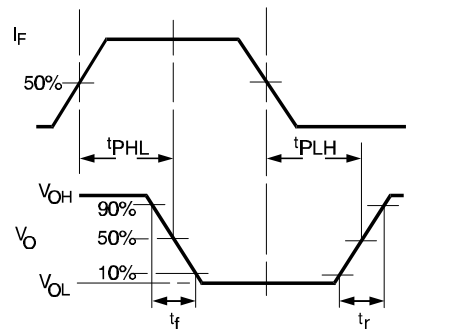

Fig. 1 Responsivity vs Angular Displacement

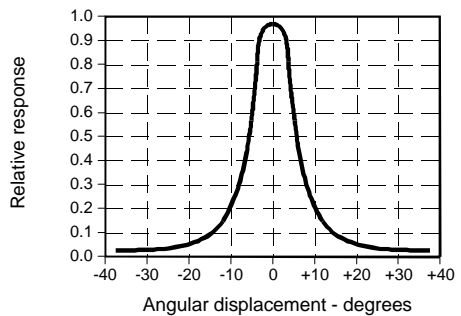
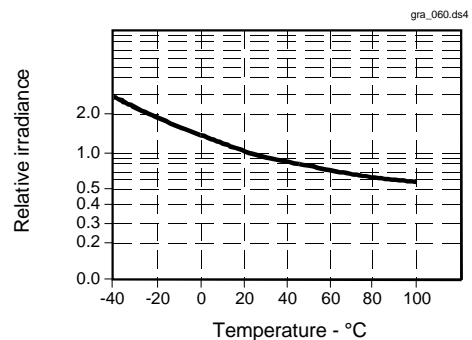

Fig. 2 Threshold Irradiance vs Temperature



SD5620/5630

Optoschmitt Detector

Fig. 3 Output Rise Time (t_r) and Output Fall Time (t_f) vs Temperature

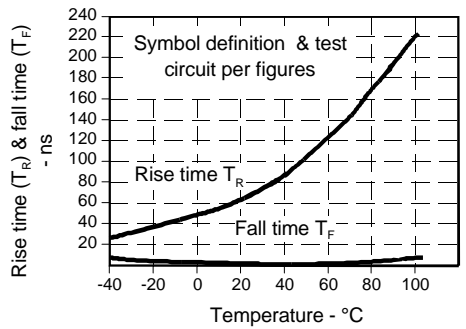

Fig. 4 Delay Time vs Temperature

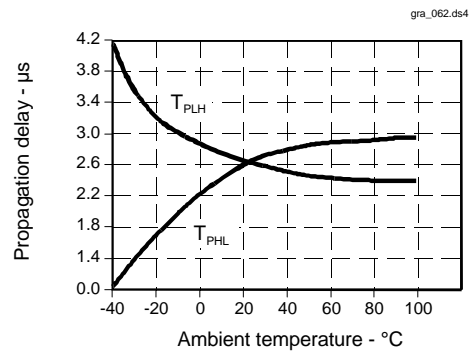
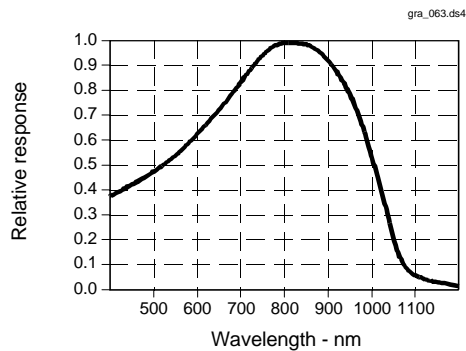

Fig. 5 Spectral Responsivity



All Performance Curves Show Typical Values

Honeywell reserves the right to make changes in order to improve design and supply the best products possible.

Honeywell

183



Elblinger Elektronik GmbH
Lange Wanne 25
38259 Salzgitter

Telefon 05341/8212-1
Fax 05341/821299

e-mail mail@elblinger-elektronik.de
Internet www.elblinger-elektronik.de