

# HOA1883

## Transmissive Sensor

### FEATURES

- Choice of phototransistor or photodarlington output
- Wide lead spacing
- 0.060 in.(1.52 mm)dia. detector aperture
- 0.140 in.(3.56 mm) slot width

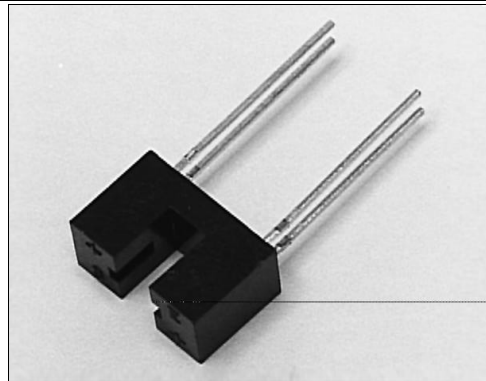

INFRA-41.TIF

### DESCRIPTION

The HOA1883 series consists of an infrared emitting diode facing an NPN silicon phototransistor (HOA1883- 011, - 012) or photodarlington (HOA1883- 013) encased in a black thermoplastic housing. Detector switching takes place whenever an opaque object passes through the slot between emitter and detector. The HOA1883 series employs plastic molded components. For additional component information see SEP8506, SDP8406, and SDP8106.

Housing material is polycarbonate. Housings are soluble in chlorinated hydrocarbons and ketones. Recommended cleaning agents are methanol and isopropanol.

### OUTLINE DIMENSIONS in inches (mm)

Tolerance 3 plc decimals  $\pm 0.010(0.25)$   
2 plc decimals  $\pm 0.020(0.51)$

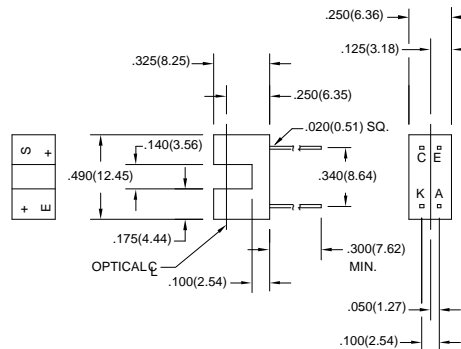

DIM\_068.dwg

# HOA1883

## Transmissive Sensor

### ELECTRICAL CHARACTERISTICS (25°C unless otherwise noted)

PARAMETER	SYMBOL	MIN	TYP	MAX	UNITS	TEST CONDITIONS
<b>IR EMITTER</b>						
Forward Voltage	$V_F$			1.6	V	$I_F=20\text{ mA}$
Reverse Leakage Current	$I_R$			10	$\mu\text{A}$	$V_R=3\text{ V}$
<b>DETECTOR</b>						
Collector-Emitter Breakdown Voltage HOA1883-011, -012 HOA1883-013	$V_{(BR)CEO}$	30 15			V	$I_C=100\ \mu\text{A}$
Emitter-Collector Breakdown Voltage	$V_{(BR)ECO}$	5.0			V	$I_E=100\ \mu\text{A}$
Collector Dark Current HOA1883-011, -012 HOA1883-013	$I_{CEO}$			100 250	nA	$V_{CE}=10\text{ V}$ $I_F=0$
<b>COUPLED CHARACTERISTICS</b>						
On-State Collector Current HOA1883-011 HOA1883-012 HOA1883-013	$I_{C(ON)}$	0.3 1.8 4.0			mA	$V_{CE}=5\text{ V}$ $I_F=20\text{ mA}$
Collector-Emitter Saturation Voltage HOA1883-011 HOA1883-012 HOA1883-013	$V_{CE(SAT)}$			0.4 0.4 1.1	V	$I_F=20\text{ mA}$ $I_C=40\ \mu\text{A}$ $I_C=230\ \mu\text{A}$ $I_C=500\ \mu\text{A}$
Rise And Fall Time HOA1883-011, -012 HOA1883-013	$t_r, t_f$			15 75	$\mu\text{s}$	$V_{CC}=5\text{ V}, I_C=1\text{ mA}$ $R_L=1000\ \Omega$ $R_L=100\ \Omega$

### ABSOLUTE MAXIMUM RATINGS

(25°C Free-Air Temperature unless otherwise noted)

Operating Temperature Range -40°C to 85°C

Storage Temperature Range -40°C to 85°C

Soldering Temperature (5 sec) 240°C

#### IR EMITTER

Power Dissipation 100 mW <sup>(1)</sup>

Reverse Voltage 3 V

Continuous Forward Current 50 mA

#### DETECTOR

Collector-Emitter Voltage 30 V

Emitter-Collector Voltage 5 V

Power Dissipation 100 mW <sup>(1)</sup>

#### Notes

1. Derate linearly at 0.78 mW/°C above 25°C.

### SCHEMATIC

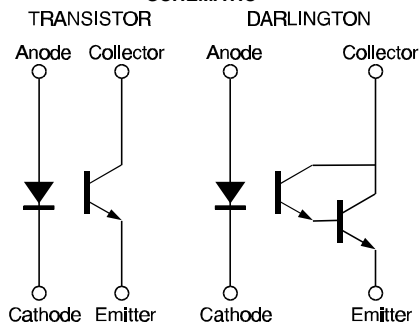

Honeywell reserves the right to make changes in order to improve design and supply the best products possible.

# Honeywell

# HOA1883

## Transmissive Sensor

Fig. 1 IRED Forward Bias Characteristics

gra\_092.ds4

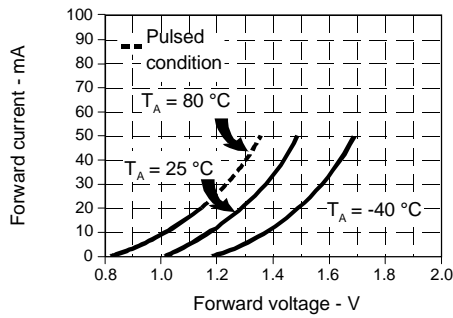

Fig. 2 Non-Saturated Switching Time vs Load Resistance

gra\_096.ds4



Fig. 3 Dark Current vs Temperature

gra\_301.cdr



Fig. 4 Collector Current vs Ambient Temperature

gra\_095.ds4



All Performance Curves Show Typical Values

**HOA1883**  
Transmissive Sensor

---

Honeywell reserves the right to make changes in order to improve design and supply the best products possible.

**Honeywell**

325



Elblinger Elektronik GmbH  
Lange Wanne 25  
38259 Salzgitter

Telefon 05341/8212-1  
Fax 05341/821299

e-mail [mail@elblinger-elektronik.de](mailto:mail@elblinger-elektronik.de)  
Internet [www.elblinger-elektronik.de](http://www.elblinger-elektronik.de)