

Pressure Sensor

Low Pressure Sensor

SLP Series

FEATURES

- Accurate low pressure readings
- Low cost
- High impedance bridge
- Low noise
- Low power consumption for battery operation

TYPICAL APPLICATIONS

- Medical instrumentation
- Portable and battery-operated equipment
- Air-flow monitoring
- HVAC
- Industrial controls



The SLP series of pressure sensors provides the lowest cost components for measuring very low pressures. These low pressure range devices were specifically designed to accurately measure differential and gage pressures of 0 inches to four inches of H₂O.

They are meant for use with non-corrosive and non-ionic media, such as air, dry gases, and the like.

These differential devices allow application of pressure to either side of the diaphragm and can be used for gage or differential pressure measurements.

WARNING

PERSONAL INJURY

DO NOT USE these products as safety or emergency stop devices or in any other application where failure of the product could result in personal injury.

Failure to comply with these instructions could result in death or serious injury.

WARNING

MISUSE OF DOCUMENTATION

- The information presented in this product sheet is for reference only. Do not use this document as a product installation guide.
- Complete installation, operation, and maintenance information is provided in the instructions supplied with each product.

Failure to comply with these instructions could result in death or serious injury.

Pressure Sensors

Low Pressure Sensor

SLP Series

ABSOLUTE MAXIMUM RATINGS

	Ratings
Supply voltage	7.5 Vdc
Temperature ranges	
Operating	0 °C to 50 °C [32 °F to 122 °F]
Storage	0 °C to 70 °C [32 °F to 158 °F]
Common mode pressure	150 in. H ₂ O
Lead temperature (soldering 2 to 4 seconds)	250 °C [482 °F]
Proof pressure	10 in H ₂ O
Burst pressure ⁽⁹⁾	5 psi

PERFORMANCE SPECIFICATIONS ⁽¹⁾

	Min.	Typ.	Max.	Unit
Operating pressure	-	-	4.0	In. H ₂ O
Sensitivity Ta = 25 °C [77 °F]	1700	2500	5500	μV/V/ In. H ₂ O
Full-scale span 4 In. H ₂ O ⁽²⁾	34	50	110	mV
Temperature coefficient of span ^(3,4)	-2850	-2400	-1950	ppm/°C
Zero pressure offset Ta = 25 °C [77 °F]	-40	0	40	mV
Temperature coefficient of offset ⁽³⁾	-	±4	-	μV/V/°C
Combined linearity and hysteresis ⁽⁵⁾	-	0.5	1.0	% FS
Long-term stability of offset and sensitivity ⁽⁶⁾	-	0.5	-	% FS
Response time (10 % to 90 %) ⁽⁷⁾	-	100	-	μS
Input resistance Ta = 25 °C [77 °F]	-	4.7	-	kOhm
Temperature coefficient of resistance ^(3,4)	2100	2300	2500	ppm/°C
Output impedance	-	4.7	-	kOhm
Repeatability ⁽⁸⁾	-	0.5	-	% FS
Position sensitivity	-	50	-	μV/V/g

SPECIFICATION NOTES

- Reference conditions: supply voltage Vs = 5 Vdc, Ta = 25 °C [77 °F]. Common-mode line pressure = 0 psig. Pressure applied to P2.
- Span is the algebraic difference between the output voltage at full-scale pressure and the output at zero pressure.
- Slope of the best straight line from 0 °C to 50 °C [32 °F to 122 °F]. For operation outside this temperature, contact factory for more specific application information.
- This parameter is not 100 % tested. It is guaranteed by process design and tested on a sample basis only.
- See definition of terms. Hysteresis is the maximum output difference at any point within the operating pressure range for increasing and decreasing pressure
- Long-term stability over a one year period.
- Response time for a 0 PSI to full-scan span pressure step change. 10 % to 90 % rise time.
- Maximum difference in output at any pressure with the operating pressure range and temperature within 0 °C to 50 °C [32 °F to 122 °F] after
 - 100 temperature cycles, 0 °C to 50 °C [32 °F to 122 °F]
 - 1.5 million pressure cycles, 0 psi to full-scale span.
- If the maximum burst pressure is exceeded, even momentarily, the package may leak or burst, or the pressure sensing die may fracture.

NOTE: Due to the delicate nature of these very sensitive devices, some special handling is required. Parts are sensitive to shock and vibration and must be handled with care. Dropping on any hard surface (bench top, etc.) can destroy the device. Note 10 in H₂O overpressure.

Pressure Sensors

Low Pressure Sensor

SLP Series

TYPICAL PERFORMANCE CHARACTERISTICS

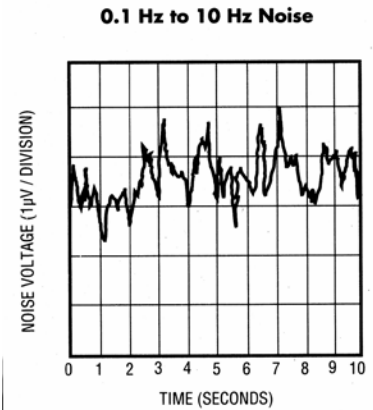
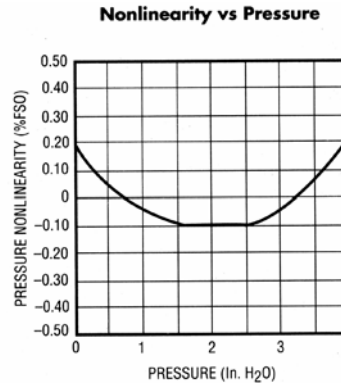
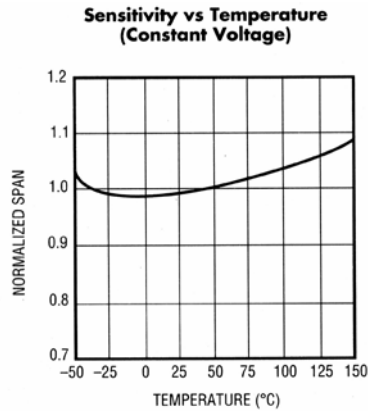

DIMENSIONAL DRAWING – BUTTON SENSOR (for reference only mm/in)

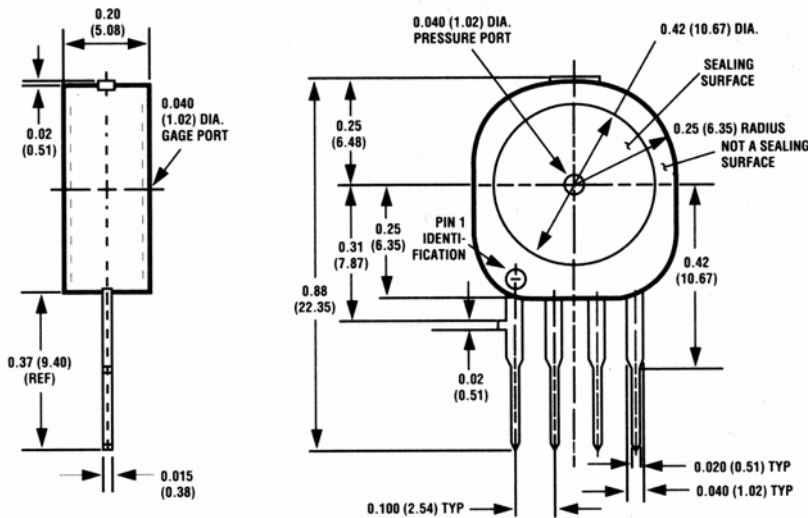

DIMENSIONAL DRAWING –D4 SENSOR (for reference only mm/in)

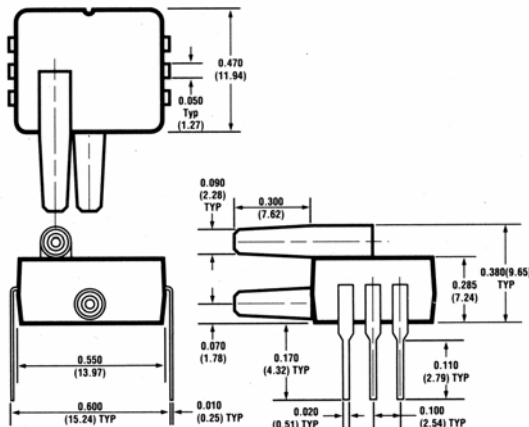

ELECTRICAL CONNECTIONS

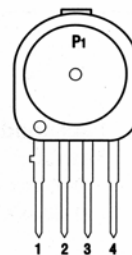

- 1) +V_S
- 2) + OUTPUT
- 3) GROUND
- 4) - OUTPUT

BUTTON PACKAGE

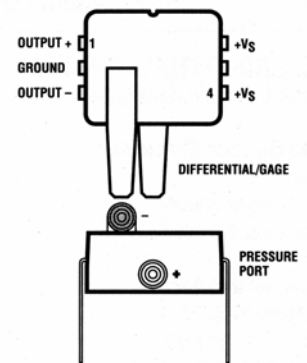

"D4" DIP PACKAGE

Pressure Sensors

Low Pressure Sensor

SLP Series

APPLICATION INFORMATION

The SLP family of pressure sensors function as a wheatstone bridge. When pressure is applied to the device, the resistors in the arms of the bridge change as shown in Figure 1. The resulting differential output voltage, V_o , is easily shown to be $V_o = V_B \times \Delta R/R$.

Since the change in resistance is directly proportional to pressure, V_o can be written as

$$V_o = S \times P \times V_B + V_{os}$$

Where,
 V_o is the output voltage in mV

S is the sensitivity in mV/V psi

P is the pressure in psi

V_B is the bridge voltage in volts

V_{os} is the offset error, (the differential output voltage when the applied pressure is zero)

FIGURE 1

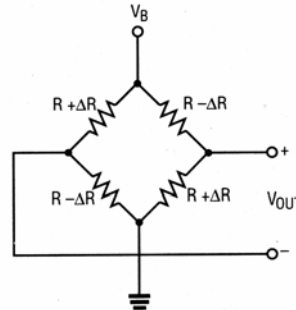
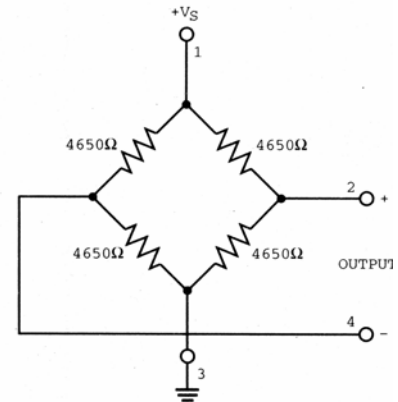

Figure 1.

EQUIVALENT CIRCUIT



ORDER GUIDE

Pressure Range	Sensor in Button Package	Sensor in DIP Package
0 in to 4 in H ₂ O	SLP004D	SLP004DD4

WARRANTY/REMEDY

Honeywell warrants goods of its manufacture as being free of defective materials and faulty workmanship. Contact your local sales office for warranty information. If warranted goods are returned to Honeywell during the period of coverage, Honeywell will repair or replace without charge those items it finds defective. **The foregoing is Buyer's sole remedy and is in lieu of all other warranties, expressed or implied, including those of merchantability and fitness for a particular purpose.**

Specifications may change without notice. The information we supply is believed to be accurate and reliable as of this printing. However, we assume no responsibility for its use.

While we provide application assistance personally, through our literature and the Honeywell web site, it is up to the customer to determine the suitability of the product in the application.

For application assistance, current specifications, or name of the nearest Authorized Distributor, contact a nearby sales office. Or call:

1-800-537-6945 USA/Canada

1-815-235-6847 International

FAX

1-815-235-6545 USA

INTERNET

www.honeywell.com/sensing

info.sc@honeywell.com

Honeywell

Sensing and Control

www.honeywell.com/sensing

Honeywell

11 West Spring Street

Freeport, Illinois 61032